

OWNER'S MANUAL

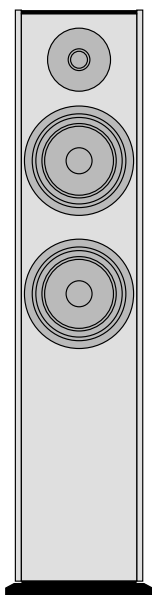

Evidence
470

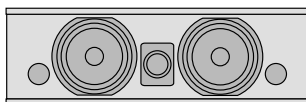

Evidence
C70

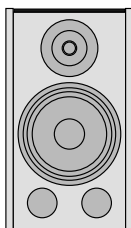

Evidence
370

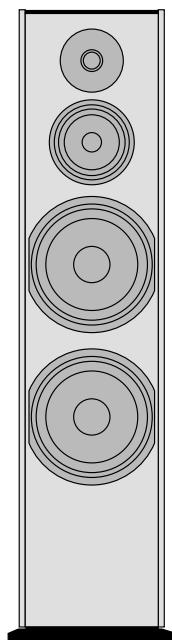

Evidence
870

PERFECT ILLUSION



Made in Denmark

THANK YOU FOR CHOOSING DALI

We know you can't wait to hear your new DALI loudspeakers, so we'll save the more technical stuff until later. That way, you'll have something to read once your system is up and running.

But first, unless you are experienced and confident in hi-fi matters, please take the time to read at least the sections on CONNECTIONS and PLACEMENT, before wiring your new DALI loudspeakers to your system.

It is the goal of this manual to assist you in obtaining the finest possible performance from your new DALI loudspeakers. If additional assistance is required, always feel free to contact your authorised DALI dealer.

STEREO AND SURROUND CONNECTION

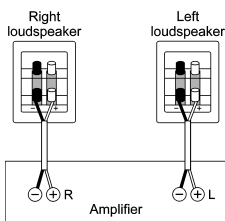

Fig. 1. Normal Stereo Connection

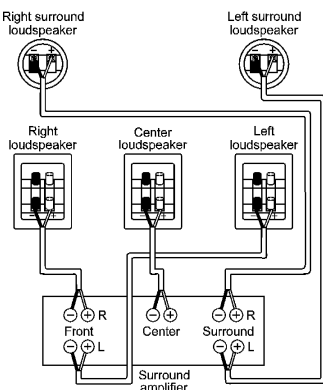

Fig. 2. Surround Connection

The loudspeaker carton indicates whether the speaker inside is Left or Right or Centre. Position them correctly.

Always turn your amplifier off before connecting or disconnecting any cables. Always use equal lengths of cable for the left and right speakers.

Cable should be connected between loudspeaker and amplifier, red plus (+) terminal to red plus (+) terminal and black minus (-) terminal to black minus (-) terminal. It is important that the connections are made correctly and „in phase.“ Incorrect, out-of-phase connection will result in a diffuse stereo image and weak bass.

Your DALI Evidence loudspeakers have two pairs of terminals. If you do not choose to use bi-wiring or bi-amping, make sure that the enclosed metal straps are in place and tightened by hand, one connecting red terminal to red terminal, the other connecting black terminal to black terminal. For normal use, connect only one terminal pair to the amp as shown in (Fig. 1).

In a surround system, connect centre, front and rear surround loudspeakers to the surround amp as shown in (Fig. 2).

BI-WIRING AND BI-AMPING

We recommend bi-wiring or bi-amping for improved sound quality.

To bi-wire or bi-amp, remove the metal straps before going on to the next steps. The top terminal pair on each speaker connects to the high frequency crossover section and the bottom terminal pair connects directly to the low frequency crossover section.

To bi-wire (fig. 3), connect cable from one pair of terminals on each speaker to the amplifier's output terminals. Then, connect another cable from the second pair of speaker terminals to the SAME terminals on the amplifier.

To bi-amp (fig. 4), two identical stereo amplifiers should be used. Connect cable from the bass terminals of the left speaker to the left channel of one of the amplifiers. Connect cable from the bass terminals of the right speaker to the right channel of the same amplifier.

Connect cable from the high frequency terminals of the left speaker to the left channel of the second amplifier. Then, connect cable from the high frequency terminals of the right speaker to the right channel of the second amplifier.

Bi-wiring offers improvements in the areas of openness and reduces intermodulation distortion. Bi-amping offers further improvements in these areas with the added benefit of increased dynamics.

Tighten all connections securely so that the cable cannot slip out. Make certain that no loose strands of wire are sticking out. Wire connected to a terminal must never touch wire connected to any other terminal.

Cable quality and design do make a difference. Buy the best cable you can reasonably afford. In this simple way, you can raise the performance of your system to a higher level.

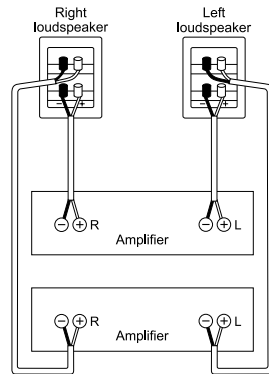
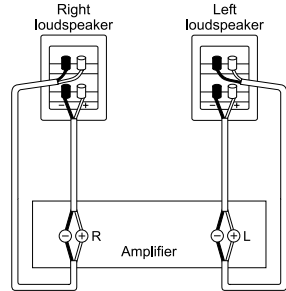

PLACEMENT

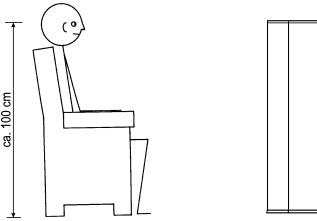

Fig. 5. Ideal height for listening

Even small differences in the positioning of loudspeakers in a room can have significant impact on performance, especially on soundstage focus and bass quality.

DALI loudspeakers are capable of exceptional performance in these and other crucial areas, but you must experiment with placement in order to find the optimum position.

Unfortunately, there are no hard and fast rules to follow, but here are a few guidelines.

There should be no objects between the speakers and the listening position. Obstructions to the free passage of sound cause uneven frequency response and poor stereo imaging.

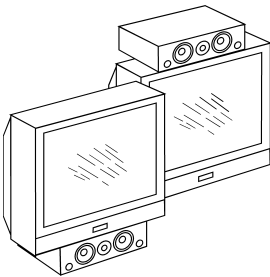

Fig. 6. Centre speaker placement

The distance between the Left and Right speaker and between each speaker and the central listening position should be identical. While DALI loudspeakers provide excellent performance at positions off to the side, for serious, critical listening we strongly recommend a central listening position.

DALI loudspeakers should face directly ahead, with no toe-in (Fig. 7).

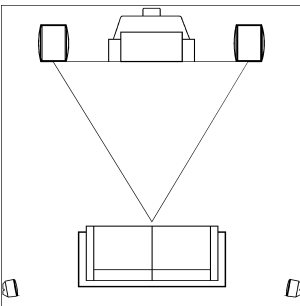

Fig. 7. Placement of stereo/surround front speakers

The DALI Evidence centre speaker is specifically tuned for placement near the large, flat surface of a TV screen. The DALI centre speaker should be placed directly above or below the television with the speaker's front edge along the same line as the TV screen (Fig. 6).

The front panel of the DALI centre speaker should be along the same line as the front panels of your left and right front speakers as seen in (fig. 7).

THE LISTENING ROOM

Your DALI loudspeakers have been designed to convert the incoming electrical signal to acoustic energy as accurately as possible. But speakers are only one link in the audio chain which begins with the quality of the recorded material, the turntable/CD player/tuner/tape player signal source, interconnects, the amplifier, speaker cables and finally ends with the listening room itself.

Loudspeakers perform best in rooms with normal furnishings such as bookshelves, flowers, vases, and soft furniture. Removing a vase, opening a curtain slightly or moving a chair a few inches can actually make a big difference. Try to avoid large, hard, flat surfaces near the speakers.

If the sound is on the bright side, closing curtains may help. The heavier the curtain, the greater the effect. Rugs or carpets will damp unwanted reflections from a hardwood floor.

The quality and quantity of bass depend on the size and shape of the room. Experiment with various positions. Bass will be reinforced by placement near side or rear walls, so, naturally, corner placement offers substantial bass boost. Find the position that offers the best balance of sound for your room and musical tastes.

When you have found the best position, make certain that the loudspeaker is perfectly level and cannot rock back and forth. Spikes may be used to couple the speaker more effectively to the floor. Spikes are especially recommended on surfaces with thick carpeting. Spikes will generally tighten up bass response and sharpen up the focus of the stereo image.

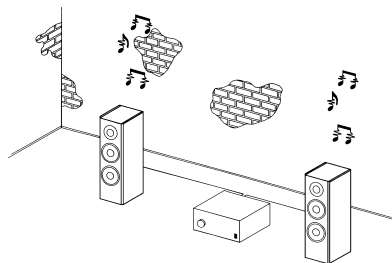
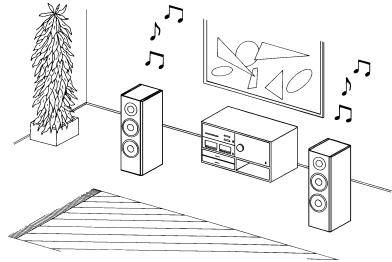

POWER HANDLING

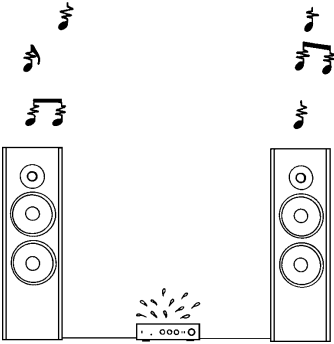

The power handling of a loudspeaker is very much dependent on the type of music it is called upon to reproduce at any given time. Since a music signal or film soundtrack simultaneously consists of a broad range of frequencies, it is not possible to define maximum power handling in meaningful terms.

In the real world, large amounts of clean, undistorted power from a big amp is better than the distorted output of a small amp pushed beyond its limits. More speakers are damaged by small amps working too hard, than by big amps coasting along.

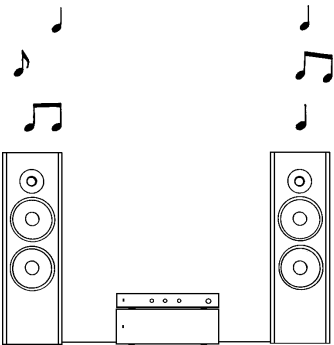

Turning tone controls up beyond their neutral centre position greatly increases power demands. Tone controls are intended for occasional use to improve older recordings or bad recordings. We strongly advise against using them to compensate permanently for weaknesses elsewhere in the audio system. Experimenting with loudspeaker placement may be all it takes to achieve a much more musical result.

Under normal conditions, overloading is heard as distortion (clipping) and a loss of clarity. If you always keep the level below this point, there will be nothing to worry about.

SURROUND SOUND

Adjusting surround levels

Follow the instructions included with your surround amplifier, match power levels so that all speakers sound equally loud at the listening position. An accurate Sound Pressure Level metre will make system calibration easier and more precise.

DYNAMICS

Unfortunately, too much attention is focused on the ability to play LOUD. Much more important for your musical and cinematic enjoyment is the ability to convey a natural sense of musical and home theatre dynamics. Dynamics is the capacity of the system to reproduce a sudden change in level (up or down) rapidly, cleanly and accurately. A system with good dynamics will present a realistic sense of the weight and scale of the musical event or film soundtrack even at low volume settings.

Try listening to your system with the volume turned down. This is a far tougher test than playing flat out at full power.

BREAK-IN PERIOD

A loudspeaker is a mechanical device and as such requires an extended initial period of normal use during which you will notice a gradual improvement in sound quality.

Wear is not a problem with DALI loudspeakers, regular use will only extend their life.

After a long period without use, the speakers may need a short break-in period again.



USEFUL NUMBERS

There are lots of measurements which can be carried out on loudspeakers, not to mention a confusing number of incompatible methods by which these measurements can be executed. But, in terms of saying something meaningful about how a given loudspeaker will actually sound, only a handful of data specifications are of any real use. You should pay special attention to specifications for sensitivity and impedance.

Sensitivity is an indication of the sound pressure level which the speaker can generate for a given input power. High sensitivity means that you can reproduce dynamic passages without spending a fortune on a high-powered amplifier.

The linear impedance of DALI loudspeakers offers ideal stress-free operating conditions for amplifiers.

Model:	EVIDENCE C70	EVIDENCE 370	EVIDENCE 470	EVIDENCE 870
Frequency response +/- 3 dB [Hz]	50 - 22000	46 - 27000	35 - 29000	35 - 29000
Impedance [ohm]	4	4	4	4
Bass reflex system resonance [Hz]	47	45.5	34	31
Crossover frequency [Hz]	2700	3700	550 3000	600 3000
Recommended amplifier power (8 ohm) [W]	40 - 150	40 - 150	30 - 200	30 - 500
Sensitivity (@2,83V/1m) [dB]	91	87.5	90	91
Max. SPL [dB]	113	107	111	113
Placement	TV / Stand	Stand / Shelf	Floor	Floor
Recommended distance from rear wall [cm]	-	10-60	50-120	50-150
Height [cm]	16.0	37.0	97.0	104.6
Width [cm]	50.0	21.0	21.5	24.4
Depth [cm]	29.8	26.2	31.5	36.8
Weight [kg/lbs]	8.2 / 18.1	7.9 / 17.4	21 / 46.3	29 / 63.9