

DALI 710 OWNERS MANUAL

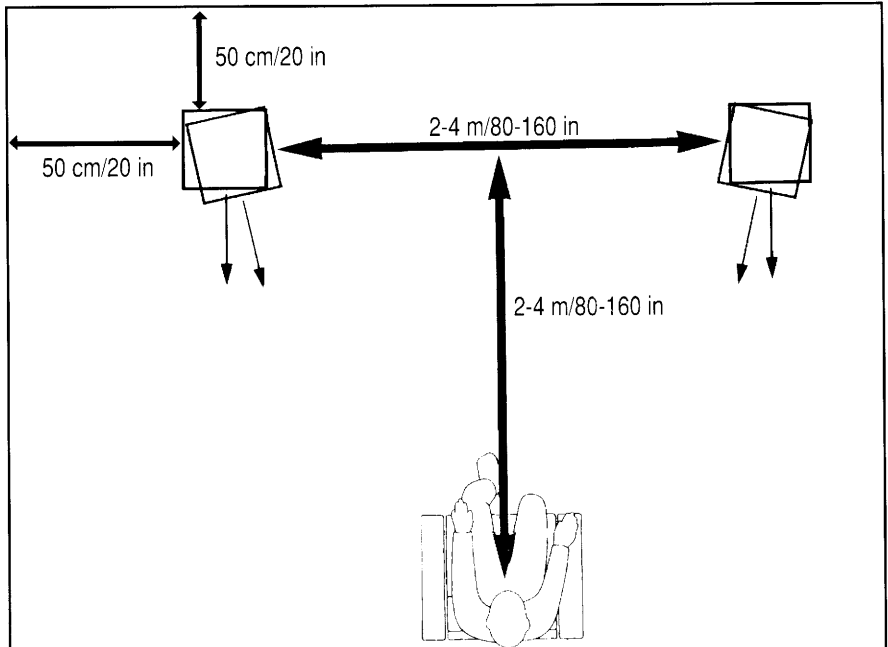

POSITIONING



CAUTION!

Dali 710 is mounted with spikes in order to improve stereo imaging. Be careful when the speakers are being moved - the spikes may damage the floor or carpet.

Congratulations on your discerning taste in selecting DALI loudspeakers. Many hours of development work and over ten years of experience are represented in your new speakers.

In order to achieve maximum performance, we recommend that you read this manual carefully before installing your new speakers.

UNPACKING

The packaging have been designed to protect the speakers from damage during transport. If any damage has occurred, please

contact your DALI dealer immediately. Be careful not to damage the diaphragms during unpacking.

POSITIONING

Please note that the speakers are provided in mirror imaged pairs, with the tweeters placed asymmetrically on the baffle, in order to minimise diffractions. The speakers are marked right (R) and left (L) on the rear panel. The speakers should NOT be angled inward towards the listening

position. The recommended positioning shown on page 2 can be used as a general guideline, but as different rooms have different influence on the sound, it may be a good idea to try various positions in order to improve the sound. For assistance, please read „Recommended Placement“.

CONNECTION

IMPORTANT!

Turn off the amplifier before connecting the loudspeakers.

The speakers are connected as shown below. For true stereo reproduction the speakers must be phased correctly. Always connect the amplifier + to the loudspeaker

+, and the amplifier - to the loudspeaker -. Always use cables designed specially for use with loudspeakers. They are often marked for correct connection. Ideally, connecting cables should be as short as possible and made of heavy duty cable, the latter being particularly important if the cable length exceeds five metres.

SPEAKER CONNECTION

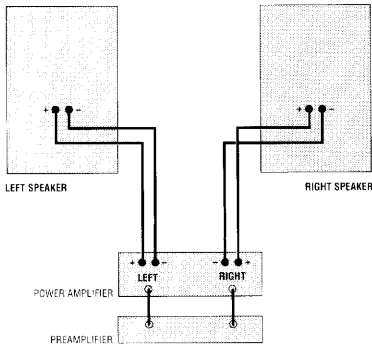

BI-WIRING

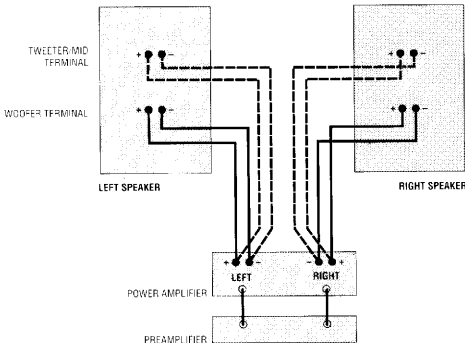

BI-AMPLING

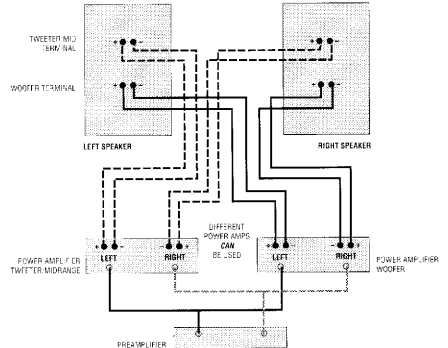

BI-WIRING/AMPING

This simply means that the low frequency drivers and the mid/high frequency drivers have separate input terminal and connection cable. When bi-amping, the low and high frequency drivers also have two separate amplifiers connected. Depending on the

equipment used, bi-wiring/bi-amping can produce significant sonic improvements, because total resistance is lower and woofer reactance is better isolated from the tweeter. When bi-amping or bi-wiring, always remove the link bars.

THE SOUND

The musical performance of your DALI speakers, like all quality loudspeakers, will improve over an initial break-in period. Please allow your new speakers to play about 30 hours of music at normal listening level, before doing any serious,

critical listening. Once broken in, they will offer a definitive rendering of the three-dimensional soundstage. If the speakers sound significant different from the sound in the shop, please read „The Listening Room“.

CARE

The only regular maintenance required is occasional cleaning of the surfaces. Dust wood surfaces with a clean, soft cloth.

Protect with high-quality furniture oil.

Enjoy the music!

RECOMMENDED PLACEMENT

Placing the speakers close to the rear wall increases the bass output, but reduces the depth of the stereo image.

Placing the speakers in corners increases the bass output further, but also makes it imprecise. At the same time, the rendering of perspective in all three dimensions will be drastically reduced and sound will more easily be perceived as coming from the speaker.

If the speakers are being placed far from reflecting walls, the

sound will lack bass output and authority.

If the listening distance is larger than the distance between the speakers, the sound can seem disengaging. Placing the listening position closer to the speakers will improve the feeling of engagement.

Angling the speakers towards the listening position is only necessary where the walls are highly absorbent.

THE LISTENING ROOM

A listening room with thick carpet, close furniture and carpet on the walls can make the sound dark and uniform.

A listening room with wooden floor without carpet, bare

walls and little furniture can make the sound aggressive and sharp.

In both cases, small changes are often enough to make the sound more neutral.

TECHNICAL SPECIFICATIONS

Sensitivity	89 dB
Nominal Impedance	8 ohm
Frequency response +/-3 dB	32-30.000 Hz
Continuous power handling	120 W
Peak power handling	180 W
Cabinet type	Bass reflex
System resonance	32 Hz
Crossover frequenc	700 Hz / 4 kHz / 10 kHz

Drivers

Bass	8"
Midrange	5"
Tweeter	2" cone - 5/8" ribbon

Dimensions

Height	97 cm
Width	28,2 cm
Depth	34 cm
Weight	30 kgs